

## These signature carousel racks provide:

- **Motor free operation eliminates all** noise, vibration, and air turbulence
- **Safe breeding environment** — especially fragile strains of research rodents
- **Eliminates 100% of odors and allergens** from the animal room
- **Ideal for all** housing applications/ experiments
- Complete **biocontainment and isolation**
- Superior **cage visibility**
- **Low stress** green housing
- Very **low annual cost** to maintain

### Optimice



### Optirat Plus



**Lose the motors and blowers.**

**Forget about maintenance costs.**

**Never worry about heat load.**

# How does our motor-free technology work?

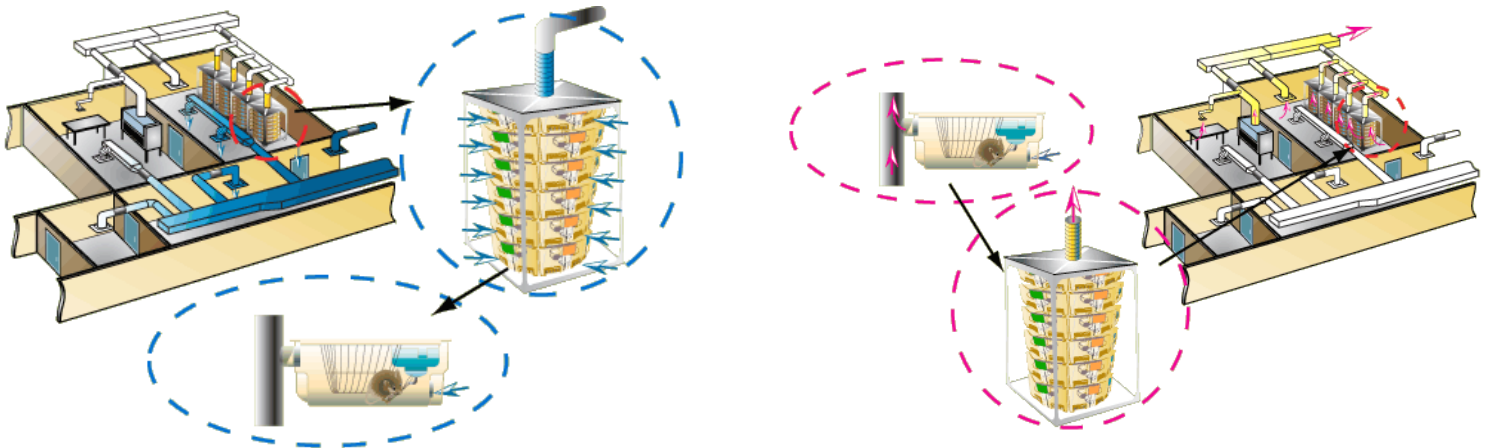

Room air is filtered through the front filters as it is drawn into each cage. The building exhaust system continues to pull the air through the cage and out the rear filter in a laminar flow.

Low-velocity, one-pass cage airflow eliminates drafts, turbulence, fast airflow and the drying effect, providing a stable microenvironment.

## Crowded animal rooms?

You don't need more space. You need denser racks.

Standard Mouse Room

**1,440  
 CAGES**

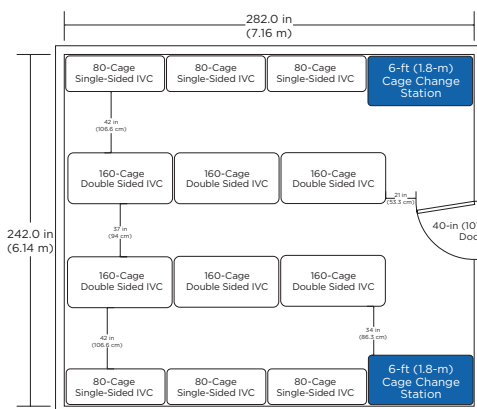

Optimice Mouse Room

**2,000  
 CAGES**

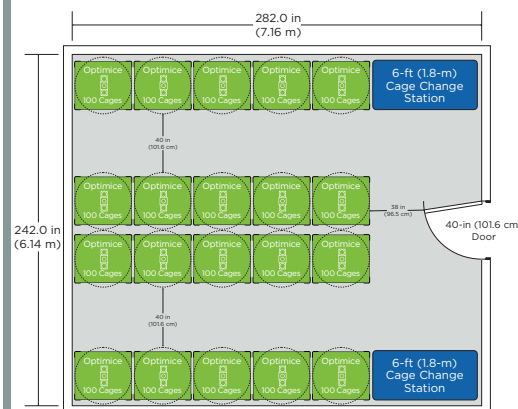

The Optimice, Optirat GenII, and Optirat Plus racks maximize animal density by reclaiming aisle space normally required for double-sided IVC racks.